



ENERGY[®]

Manufacturing Company, Inc.

CYL SERIES MEDIUM-DUTY CUSTOM WELDED HYDRAULIC CYLINDERS

**Bore Diameters:
1" to 7" (2.54 cm to 17.8 cm)**

**Stroke Lengths:
to 15' (4.57 m)**

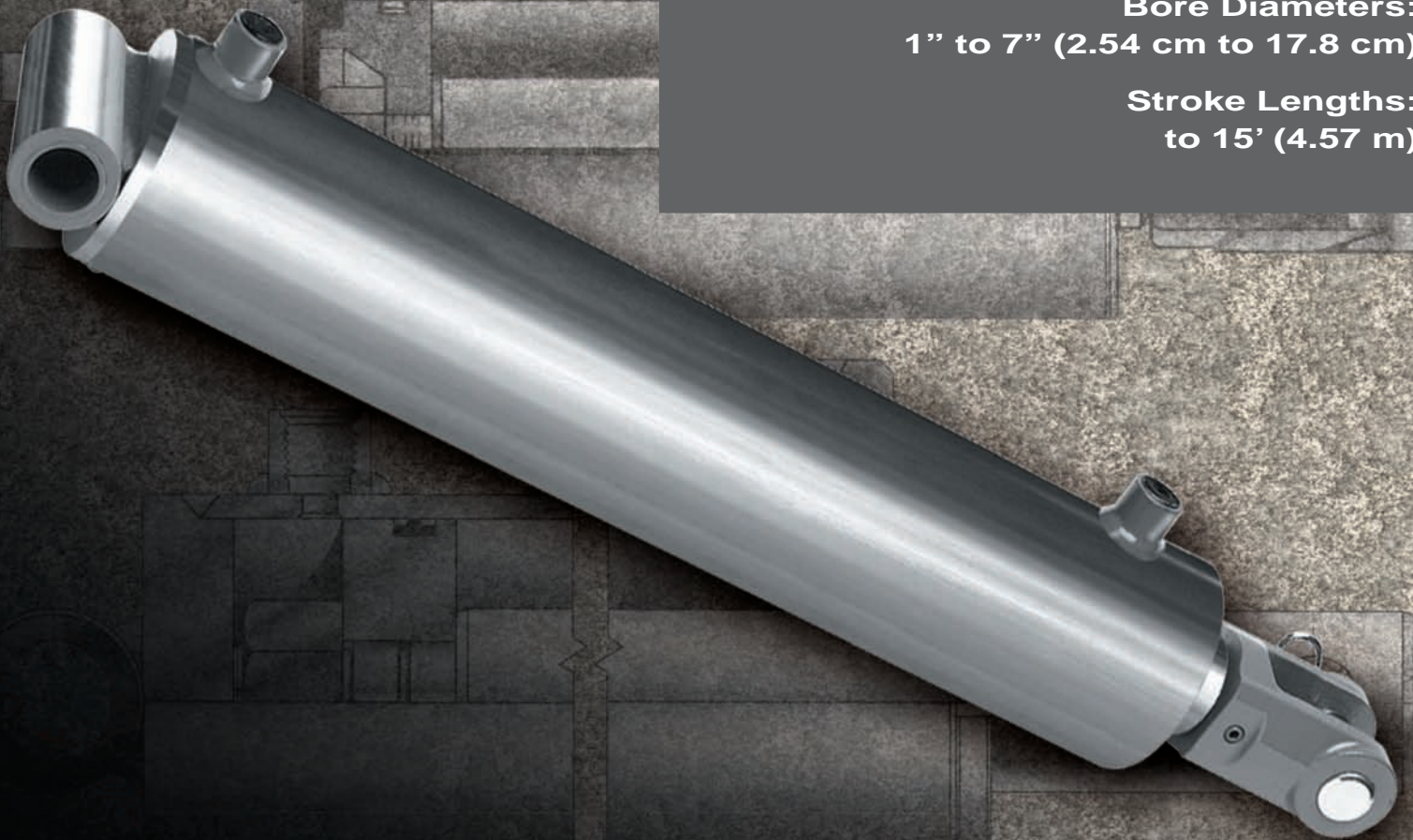

For Working Pressures to 3000 PSIG (207BAR)

CYL HYDRAULIC CYLINDER DESIGN

CYL WELDED CONSTRUCTION

Energy®'s CYL Series Welded Cylinders Feature:

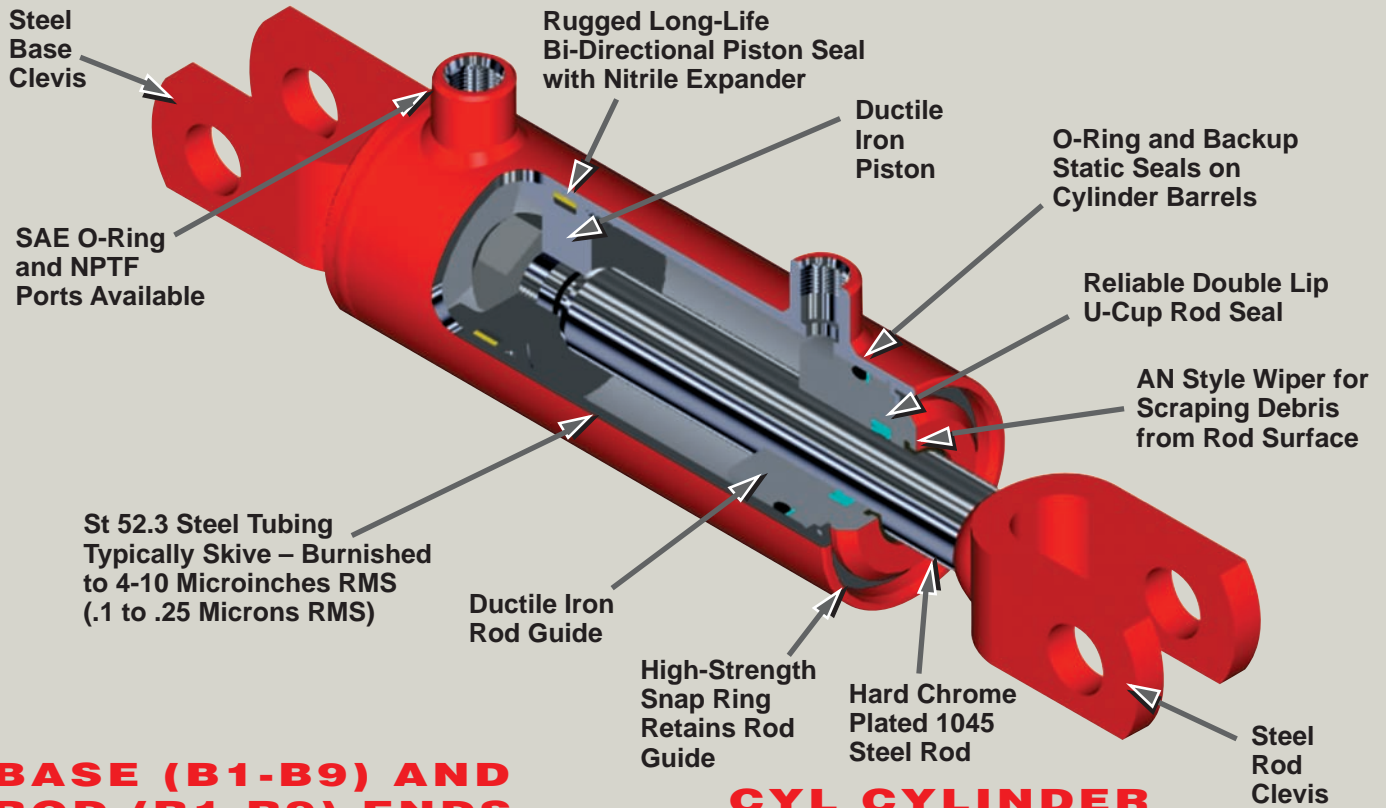

BASE (B1-B9) AND ROD (R1-R9) ENDS

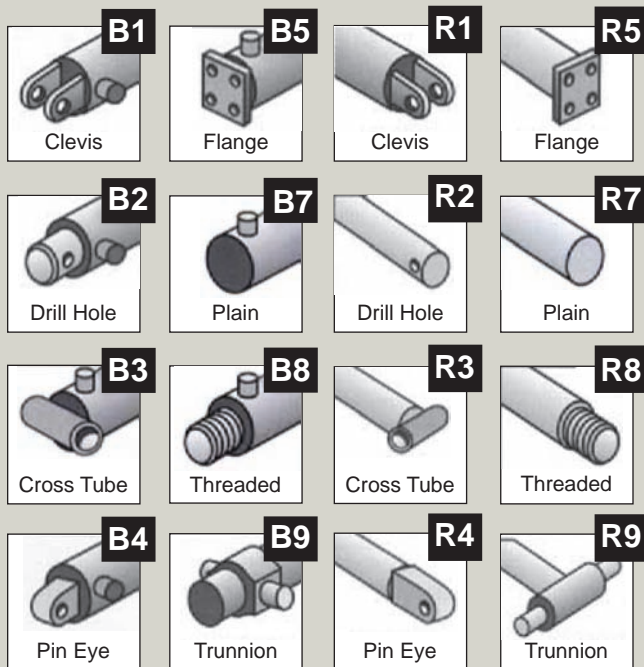

NOTE: Custom base and rod ends, as well as other custom cylinder features, may be available upon request. Please contact our factory for additional information.

CYL CYLINDER DIMENSIONS

Bore Diameter	Available Rod Diameters
1.5" (3.8cm)	.75" (1.9cm), 1" (2.5cm)
2.0" (5.1cm)	1.125" (2.9cm), 1.25" (3.2cm)
2.5" (6.4cm)	1.125" (2.9cm), 1.25" (3.2cm), 1.5" (3.8cm)
3.0" (7.6cm)	1.125" (2.9cm), 1.25" (3.2cm), 1.5" (3.8cm), 1.75" (4.4cm), 2" (5.1cm)
3.5" (8.9cm)	1.5" (3.8cm), 1.75" (4.4cm), 2" (5.1cm)
4.0" (10.2cm)	1.5" (3.8cm), 1.75" (4.4cm), 2" (5.1cm), 2.5" (6.4cm)
4.5" (11.4cm)	1.75" (4.4cm), 2" (5.1cm), 2.5" (6.4cm)
5.0" (12.7cm)	2" (5.1cm), 2.25" (5.7cm), 2.5" (6.4cm), 3" (7.6cm)
6.0" (15.2cm)	3" (7.6cm), 4" (10.2cm)
7.0" (17.8cm)	3" (7.6cm), 4" (10.2cm)

Please contact factory if the bore/rod combination you desire is not shown above.

CYL DESIGN OPTIONS & SPECIAL PORT BLOCKS

SPECIAL VALVE BLOCK (BOLTED ON)

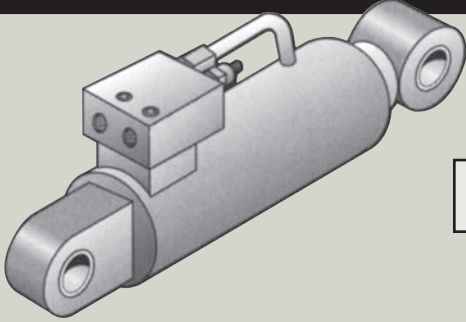

*Illustration is one typical example.
For other options consult factory.*

SPECIAL VALVE BLOCK IN BASE END

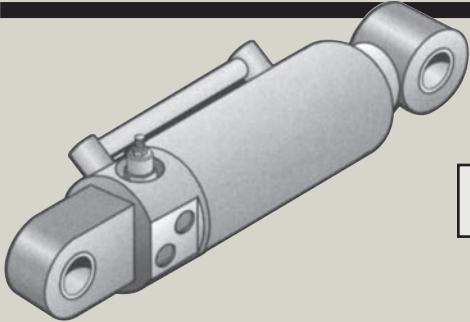

*Illustration is one typical example.
For other options consult factory.*

PORT OPTIONS AVAILABLE

- **Standard SAE O-Ring Ports:**
Available in straight, 90° elbow, and several other configurations
- **NPTF Ports:**
Available in straight, 90° elbow, and several other configurations
- **4-Bolt Flange Ports:**
Please consult factory for availability

ADDITIONAL AVAILABLE FEATURES:

- Single-acting cylinders
- Ram-type cylinders
- Custom end mechanisms
- Custom fluid lines
- Hydraulic cushioning
- Integral stop tubes
- Custom valve blocks and valves
- Position sensing cylinders
- Re-phasing cylinders

ENERGY MANUFACTURING CUSTOM WELDED CYLINDER EXAMPLES

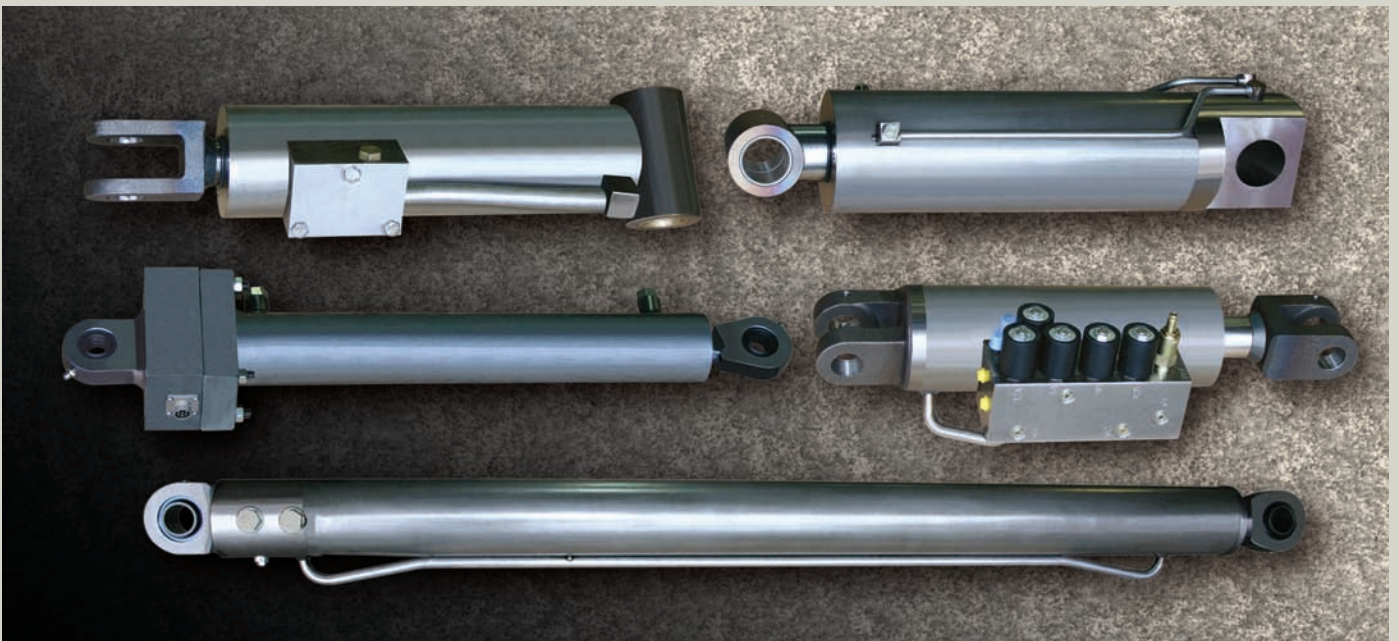

CUSTOM QUOTATION REQUEST

All Energy® welded cylinders are custom-made.

Please complete and return the following sheet so that we can provide you with the best cylinder for your application.

ENERGY Custom Quotation Request Form

This form must be filled out in its entirety before a welded cylinder quotation can be prepared. Unless noted otherwise by the customer, Energy® Manufacturing will use the following parameters with respect to the processing of this request:

1. The oil temperature in the cylinder will be 170° Fahrenheit (77° Celsius) or less.
2. The rod speed will be 50 feet per minute (15.2 meters per minute) or less.
3. System filtration will be 20 micron or better.
4. The fluid used is SAE 20 (ISO VG68) or less-viscous petroleum-based fluid and is non-foaming type for hydraulic use.
5. Mount center-to-center and stroke dimensions are +/- 1/8" (+/-3.2 mm).
6. The cylinder is not used in a corrosive environment.

PURPOSE OF QUOTE: _____

QUOTE DEADLINE DATE: _____

CUSTOMER DATA

Customer name: _____ Customer part number: _____
Address: _____
City, State or Province, Zip or Postal Code, Country: _____
Telephone number: _____ Purchasing contact: _____
Fax number: _____ Engineering contact: _____
E-mail: _____

CYLINDER DATA

All welded cylinder quotation requests should be accompanied by a blueprint or sketch and the following data should be completed. Cushioned cylinder requests must include pump flow to cylinder, weight of load, and details of the linkage between cylinder and load.

Bore size: _____ Mountings:
Stroke length: _____ Base: _____
Rod diameter: _____ Rod: _____
Retracted pin center-to-center length: _____ Finish:
Port type(s) (examples: NPT, NPTF, SAE O-Ring, Acrylic Water-Based Primer Paint
4-Bolt Flange, etc.) _____ (please specify color): _____
Port size(s): _____ Acrylic Water-Based Finish Paint
Mounting pin diameter(s): _____ (please specify color): _____
Test requirements: Other Painting (please specify type and color): _____
() Standard 100% air test () 100% Hydraulic test Clear Rust-Preventative Coating: _____
None: _____

QUOTATION DATA

Annual Usage: _____ Release Quantity: _____
Target Price: _____

APPLICATION DATA

Type of machine (crane, combine, etc.): _____ Primary cylinder effort will be to () push load
() pull load () both push and pull load
Will cylinder be used to lift people? _____ Cylinder is () double acting () single acting
Type of function (hoist, swing, steering, etc.): _____ Cylinder is mounted () vertically () horizontally
() swings through arc with mechanism
Estimated cycles per year: _____
Does cylinder always reach full extend or retract position? _____ Pressure values:
Operating: _____
Is cylinder subjected to high overrunning loads? _____ Peak: _____
Is cylinder subjected to side loading? _____ Main system relief: _____
Is cylinder barrel braced to restrict buckling? _____ Operating flow range: _____

ENERGY®
Manufacturing Company, Inc.

Energy® is a member of:
NFPA (National Fluid Power Association)

00.336.1



ISO
9001:2008

Energy® Mfg. Co., Inc.

204 Plastic Lane • Monticello, IA 52310-9472 • USA

Phone: (319) 465-3537 • Fax: (319) 465-5279 • Web Site: www.energymfg.com • E-mail: info@energymfg.com

©2011 Energy® Manufacturing Company, Inc.
Form No. CYL (Rev. 5/11)